

feeders & valves



Industrial Equipment & Design Company

Feeders & Valves

An integral part of many powder handling systems is the “feeder” or valve to provide the controlled feed of product into the process. **IEDCO** is proud to be the Exclusive North American distributor for **MEI Valves** (*pronounced “May”*).



MEI Valvole Industriali has been a leading Italian manufacturer of valves and valve accessories for the past 20 years. Today they have a company with avant-garde technology and an innovative spirit. MEI Valves are currently being used in the Pharmaceutical, Chemical and Food industries throughout the world.

Technology and innovation, together with the extensive experience of the founders, have contributed to the constant expansion of the company and acquisition of new sectors of the market. "Quality in service and in product" is the motto of MEI Valvole Industriali, and their high standards are easily seen in their accurate, consistent and efficient valves.

Unlike other valve companies, MEI designs and manufactures all their valves 100%. This allows them, and us, to offer their highly accurate valves at an extremely competitive price versus their competitors.

Butterfly Valve

The **BUTTERFLY VALVE** sets the standard in hygiene and cleanliness for the handling of powders, granules, pastes, liquids and gases in the hygiene conscious industries.

The **BUTTERFLY VALVE** offers superior quality coupled with the latest design and technology available for a butterfly valve.

The product range also includes connection systems between different processes. Sealing against pressure and vacuum - Quick release by "CLAMP" - Very light and thin - Available with manual handle or with pneumatic actuators in sizes from 4" to 12" with standard sanitary ferrule connections.



Rotary Valves

The **ROTARY VALVE** allows continuous feeding of granules and powders without flow obstruction. Its use is ideal for feeding of: mills, tablet press machines, capsule filling machines, micro-dosing machines, sieving machines. A 6 pocket rotor (8 on request) turns back and forth introducing a uniform quantity of product.

The **ROTARY VALVE's** unique design provides a flow control system in far less space and with smallest dimensions than conventional star valves.

The **ROTARY VALVE** has been developed to provide uniform dosing of product. Its star configuration and its movement (alternating 180 degrees in one direction and 180 degrees in the other direction) supplies product and transfers it into the machine below by keeping above that contained in the feeding receiver. The reciprocating movement prevents separation. The operation of the valve movement can be regulated as required and, with the proper controls, can be used as an accurate batch feeder.



Tablet Valve

The **TABLET VALVE** offers an ideal solution for handling capsules, tablets, pills, silicone caps, etc... Its silicone coated disc allows opening and closing of the valve without any damage to the product

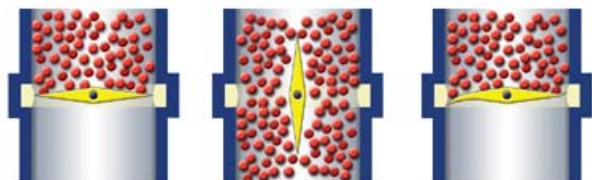

The **TABLET VALVE** vane is silicone coated and its outer surface is flexible. This allows opening and closing of the valve without damaging the product. The silicone is of medical grade material based on the standards of Pharmacopeia FDA 21 CFR 177.2600.



Valve Assembly Types

Bolt Together Models (w/stainless steel bolts)

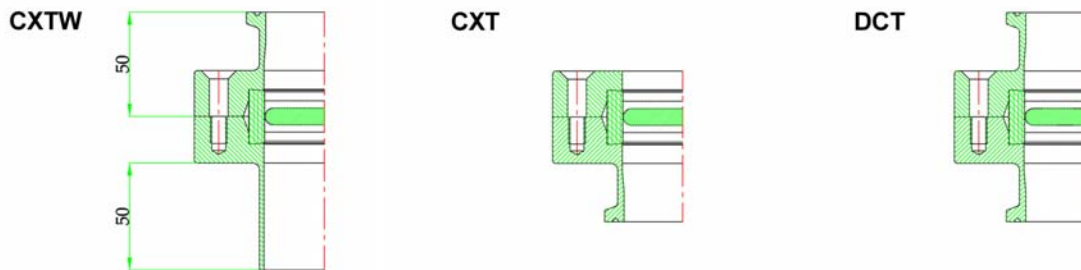

Clamp Together Models (w/stainless steel clamp)

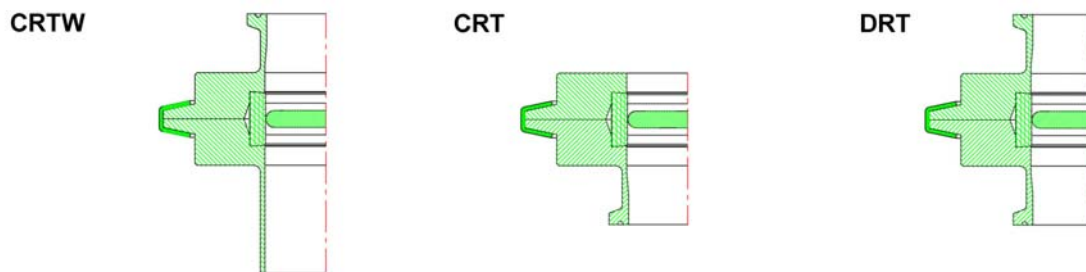

Control Systems

Pneumatic Actuator

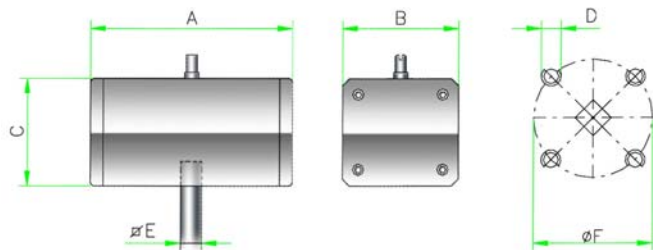

Materials Available:

Anodized Aluminum (standard)
Stainless Steel

USD	DN	Model	A	B	C	D	E	F
4"	100	APM1	164	75	66	M5	11x11	42
6" : 8"	150 : 200	APM2	199	90	81	M6	11x11	50
10"	250	APM2	199	90	81	M6	14x14	50
12	300	APM3	258	110	100	M8	17x17	70

Sanitized Manual Handle (stainless steel w/ self-locking mechanism)

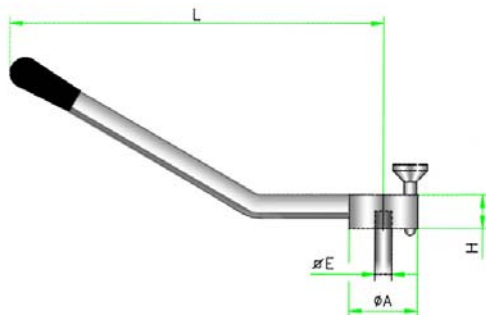

USD	DN	A	E	H	L
4"	100	50	11	24	240
6"	150	50	11	24	295
8"	200	50	11	24	295
10"	250	50	14	24	340
12"	300	50	17	24	380



...a world of experience to meet your powder handling challenges

Getting Powder & Tablets From Point “A” To Point “B” Is Our Only Business



Specializing In

- Engineering & Systems Integration ■ Bag Handling
- Batch Systems & Dispensaries ■ Bulk Bag Filling & Unloading ■
- Containment Systems ■ Control Systems ■ Tablet Handling
- Intermediate Bulk Containers ■ Column Lifts, Blenders & Wash Stations ■
- Drum Handling ■ Sampling Systems ■ Vacuum Conveying Systems
- Feeders & Valves ■ Filling & Packaging Systems



Industrial Equipment & Design Company 110 American Blvd., Ste 1 Turnersville, NJ 08012
Phone: 856.728.6400 Fax: 856.728.6460 www.iedco.com info@iedco.com